

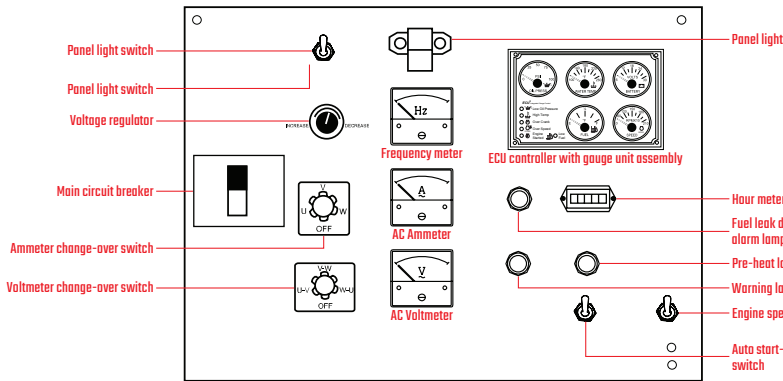

**Generator Control Panel**

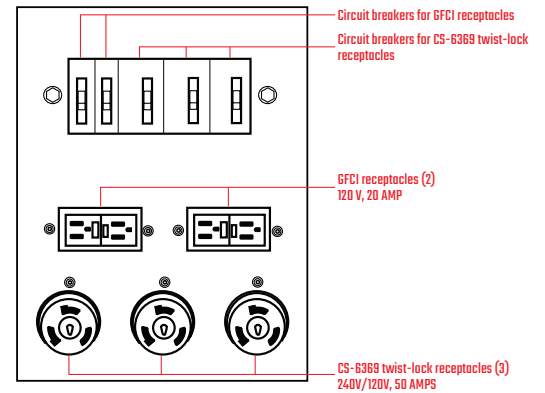

**Generator Output Panel**



**DCA125SSIU4F Weights\***

Dry Weight	5,291 lbs. (2,400 kg)
Wet Weight	6,702 lbs. (3,040 kg)
Max. Lifting Point Capacity	14,050 lb. (6,370 kg)

\* Weights do not include options

**DCA125SSIU4F Dimensions (with trailer)**

Length	181.18 in (4602 mm)
Width	79.7 in (2024 mm)
Height	101.2 in (2570 mm)



### Generator Specifications

Design	Revolving field, self-ventilated Drip-proof, single bearing	
Armature Connection	Star with Neutral	Zig Zag
Phase	3	Single
Standby Output	110KW (137.5 KVA)	79 KW
Prime Output	100 KW (125 KVA)	72 KW
3Ø Voltage (L-L/L-N) Voltage Selector Switch at 3Ø 240/139	208V/120, 220V/127, 240V/139	N/A
3Ø Voltage (L-L/L-N) Voltage Selector Switch at 3Ø 480/277	416V/240, 440V/254, 480V/277	N/A
1Ø Voltage (L-L/L-N) Voltage Selector Switch at 1Ø 240/120	N/A	240/120
Power Factor	0.8	1.0
Voltage Regulation (No load to full load)	±0.5%	
Generator RPM	1800	
Frequency	60 Hz	
Winding Pitch	2/3	
No. of Poles	4	
Excitation	Brushless with AVR	
Frequency Regulation: No Load to Full Load	Isochronous under varying loads from no load to 100% rated load	
Frequency Regulation: Steady State	±0.25% of mean value for constant loads from no load to full load	
Insulation	Class F	
Sound Level dB(A) Full load at 23 feet	66	

### Engine Specifications

Make / Model	Isuzu / BR-4HKIX
Emissions	EPA Tier 4 Final Certified
Starting System	Electric
Design	4-cycle, water cooled, direct injection, turbocharged, charge air cooled, DDC and SCR
Displacement	317 in <sup>3</sup> (5193 cc)
No. cylinders	4
Bore x Stroke (mm)	4.52 x 4.92 in. (115 x 125 mm)
Gross Engine Power Output	170.8 hp (127.4 kW)
BMEP	211 psi (1458 kPa)
Piston Speed	1476 ft/min (7.5 m/s)
Compression Ratio	16.5:1
Engine Speed	1800 rpm
Overspeed Limit	2070 rpm
Oil Capacity	6.05 gallons (22.9 liters)
Battery	12V 150Ah x 1

### Fuel System

Recommended Fuel	ASTM-D975-No.1 & No.2-D*	
Maximum Fuel Flow (per hour)	19 gallons (71.9 liters)	
Maximum Inlet Restriction (Hg)	2.9 in. (73.6 mm)	
Fuel Tank Capacity	169 gallons (640 liters)	
<b>Fuel Consumption</b>	<b>gph</b>	<b>lph</b>
At full load	7.1	26.9
At 3/4 load	5.6	21.2
At 1/2 load	4.1	15.5
At 1/4 load	2.6	10.0
DEF Tank Capacity	7.4 gallons (28 liters)	

\* Use ultra-low sulfur diesel fuel

### Cooling System

Fan Load	6.57 hp (4.9 kW)
Coolant Capacity (with radiator)	10.3 gallons (39 liters)
Coolant Flow Rate (per minute)	60.8 gallons (230 liters)
Heat Rejection to Coolant (per minute)	4456 Btu (4.7 MJ)
Maximum Coolant Friction Head	1.1 psi (7.7 kPa)
Maximum Coolant Static Head	3.3 feet (1.0 meter)
Ambient Temperature Rating	104°F (40°C)

### Air

Combustion Air	244 cfm (6.9 m <sup>3</sup> /min)
Maximum Air Cleaner Restriction	25 in. H <sub>2</sub> O (6.25 kPa)
Alternator Cooling Air	1352 cfm (38.3 m <sup>3</sup> /min)
Radiator Cooling Air	6005 cfm (170 m <sup>3</sup> /min)

### Exhaust System

Gas Flow (full load)	512 cfm (14.5 m <sup>3</sup> /min)
Gas Temperature	658°F (348°C)
Maximum Back Pressure	100 in. H <sub>2</sub> O (25 kPa)

### Amperage

Rated Voltage	Maximum Amps
1Ø 120 Volt	300A x 2 (Zigzag)
1Ø 240 Volt	300 A (Zigzag)
3Ø 208 Volt	300 Amps
3Ø 240 Volt	300 Amps
3Ø 480 Volt	150 Amps
Main Line Circuit Breaker Rating	300 Amps
Over Current Relay Trip Set Point 480V Mode Only	152 Amps

### PowerBalance Load Bank

Rated Voltage	Maximum Amps
kW Rating	35
3Ø 240/480 Volt	84/42 Amps
Fuses	125 Amps x 3

