

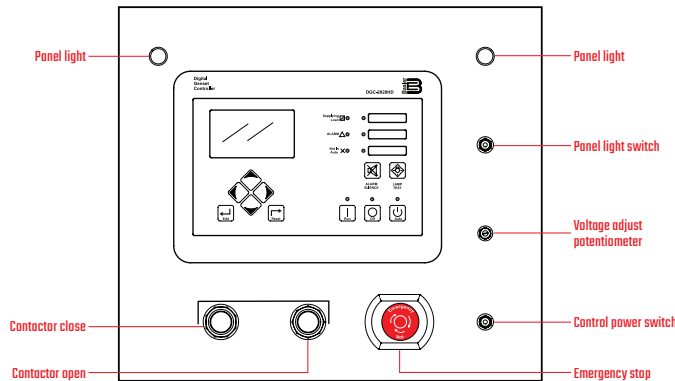

**Generator Control Panel**

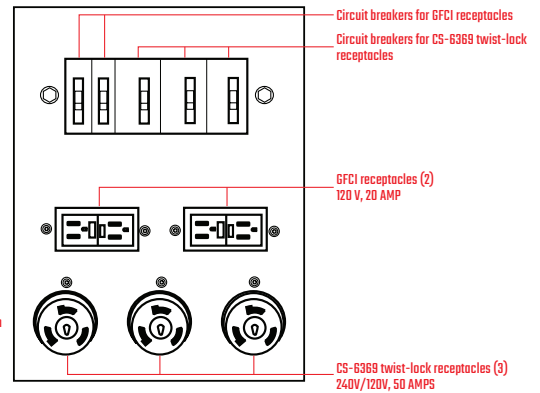

**Generator Output Panel**



**DCA220SSJU4F3 Weights\***

Dry Weight	8,399 lbs. (3,810 kg)
Wet Weight	11,111 lbs. (5,040 kg)
Max. Lifting Point Capacity	16,500 lbs. (7,483 kg)

\* Weights do not include options

**DCA220SSJU4F3 Dimensions (with trailer)**

Length	212.9 in (5408 mm)
Width	89 in (2261 mm)
Height	105.4 in (2677 mm)



Generator Specifications	
Design	Revolving field, self-ventilated Drip-proof, single bearing
Armature Connection	Star with Neutral
Phase	3
Standby Output	194 KW (242 KVA)
Prime Output	176 KW (220 KVA)
3Ø Voltage (L-L/L-N) Voltage Selector Switch at 3Ø 240/139	208Y/120, 220Y/127, 240Y/139
3Ø Voltage (L-L/L-N) Voltage Selector Switch at 3Ø 480/277	416Y/240, 440Y/254, 480Y/277
1Ø Voltage (L-L/L-N) Voltage Selector Switch at 1Ø 240/120	N/A
Power Factor	0.8
Voltage Regulation (No load to full load)	±0.5%
Generator RPM	1800
Frequency	50/60 Hz
Winding Pitch	2/3
No. of Poles	4
Excitation	Brushless with AVR
Frequency Regulation: No Load to Full Load	Isochronous under varying loads from no load to 100% rated load
Frequency Regulation: Steady State	±0.25% of mean value for constant loads from no load to full load
Insulation	Class F
Sound Level dB(A) Full load at 23 feet	69

Engine Specifications	
Make / Model	John Deere / 6068HFG06
Emissions	EPA Tier 4 Final Certified
Starting System	Electric
Design	4-cycle, water cooled, direct injection, turbocharged, charge air cooled, EGR, DOC, and SCR
Displacement	414.96 in <sup>3</sup> (6.8 liters)
No. cylinders	6
Bore x Stroke (mm)	4.17 x 5.0 in. (106 x 127 mm)
Gross Engine Power Output	323 hp (241 kW)
BMEP	316 psi (2180 kPa)
Piston Speed	1500 ft/min (7.62 m/s)
Compression Ratio	17.2:1
Engine Speed	1800 rpm
Overspeed Limit	2070 rpm
Oil Capacity	8.58 gallons (32.5 liters)
Battery	12V 150Ah x 1

Fuel System		
Recommended Fuel	ASTM-D975-No.1 & No.2-D*	
Maximum Fuel Flow (per hour)	44.3 gallons (168 liters)	
Maximum Inlet Restriction (Hg)	8.9 in (225 mm)	
Fuel Tank Capacity	319 gallons (1210 liters)	
<b>Fuel Consumption</b>	<b>gph</b>	<b>lph</b>
At full load	12.0	45.5
At 3/4 load	9.4	35.5
At 1/2 load	6.9	26.1
At 1/4 load	4.6	17.3
DEF Tank Capacity	29.8 gallons (112.8 liters)	

\* Use ultra-low sulfur diesel fuel

Cooling System	
Fan Load	9.6 hp (7.2 kW)
Coolant Capacity (with radiator)	12.9 gallons (48.7 liters)
Coolant Flow Rate (per minute)	119 gallons (450 liters)
Heat Rejection to Coolant (per minute)	6,944 Btu (7.33 MJ)
Maximum Coolant Friction Head	7.3 psi (50 kPa)
Maximum Coolant Static Head	78.6 ft. (24.0 m)
Ambient Temperature Rating	104°F (40°C)

Air	
Combustion Air	537 cfm (15.2 m <sup>3</sup> /min)
Maximum Air Cleaner Restriction	25 in. H <sub>2</sub> O (6.25 kPa)
Alternator Cooling Air	1459 cfm (41.3 m <sup>3</sup> /min)
Radiator Cooling Air	9,450 cfm (267.5 m <sup>3</sup> /min)

Exhaust System	
Gas Flow (full load)	1119 cfm (31.7 m <sup>3</sup> /min)
Gas Temperature	752°F (400°C)
Maximum Back Pressure	78 in. H <sub>2</sub> O (19.6 kPa)

Amperage	
Rated Voltage	Maximum Amps
1Ø 120 Volt	488.9 Amps (4 wire)
1Ø 240 Volt	244.4 Amps (4 wire)
3Ø 208 Volt	529 Amps
3Ø 240 Volt	529 Amps
3Ø 480 Volt	264 Amps
Main Line Circuit Breaker Rating	600 Amps
Over Current Relay Trip Set Point 480V Mode Only	256 Amps

PowerBalance Load Bank	
Rated Voltage	Maximum Amps
kW Rating	61.6
3Ø 240/480 Volt	148/74 Amps
Fuses	175 Amps x 3

