

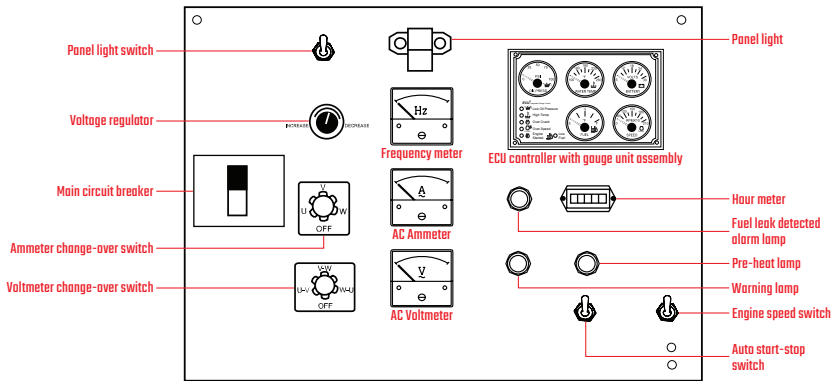

Generator Control Panel

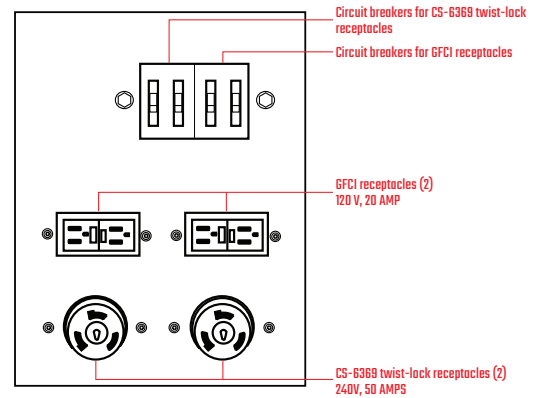

Generator Output Panel



DCA25SSIU4F Weights*

Dry Weight	1,795 lbs. (814 kg)
Wet Weight	2,137 lbs. (969 kg)
Max. Lifting Point Capacity	5,150 lbs. (2,335 kg)

* Weights do not include options

DCA25SSIU4F Dimensions (with trailer)

Length	105.81 in (2687.57 mm)
Width	56.13 in (1425.70 mm)
Height	65.30 in (1658.62 mm)



Generator Specifications

Design	Revolving field, self-ventilated Drip-proof, single bearing	
Armature Connection	Star with Neutral	Zig Zag
Phase	3	Single
Standby Output	22 KW (27.5 KVA)	15.8 KW
Prime Output	20 KW (25 KVA)	14.4 KW
3Ø Voltage (L-L/L-N) Voltage Selector Switch at 3Ø 240/139	208V/120, 220V/127, 240V/139	N/A
3Ø Voltage (L-L/L-N) Voltage Selector Switch at 3Ø 480/277	416V/240, 440V/254, 480V/277	N/A
1Ø Voltage (L-L/L-N) Voltage Selector Switch at 1Ø 240/120	N/A	240/120
Power Factor	0.8	1.0
Voltage Regulation (No load to full load)	±0.5%	
Generator RPM	1800	
Frequency	60 Hz	
Winding Pitch	5/6	
No. of Poles	4	
Excitation	Brushless with AVR	
Frequency Regulation: No Load to Full Load	Isochronous under varying loads from no load to 100% rated load	
Frequency Regulation: Steady State	±0.25% of mean value for constant loads from no load to full load	
Insulation	Class F	
Sound Level dB(A) Full load at 23 feet	65	

Engine Specifications

Make / Model	Isuzu / 4LE2T
Emissions	EPA Tier 4 Final Certified
Starting System	Electric
Design	4-cycle, water cooled, direct injection, turbocharged, and EGR
Displacement	133.0 in ³ (2178 cc)
No. cylinders	4
Bore x Stroke (mm)	85 x 96
Gross Engine Power Output	40.2 hp (30 kW)
BMEP	133 psi (918 kPa)
Piston Speed	1133.9 ft./min. (5.76 m/s)
Compression Ratio	17.6:1
Engine Speed	1800 rpm
Overspeed Limit	2070 rpm
Oil Capacity	2.8 gallons (10.5 liters)
Battery	12V 53Ah x 1

Fuel System

Recommended Fuel	ASTM-D975-No.1 & No.2-D*	
Maximum Fuel Flow (per hour)	2.3 gallons (8.8 liters)	
Maximum Inlet Restriction (Hg)	6.8 in. (173 mm)	
Fuel Tank Capacity	41.7 gallons (158 liters)	
Fuel Consumption	gph	lph
At full load	1.62	6.12
At 3/4 load	1.26	4.77
At 1/2 load	0.94	3.57
At 1/4 load	0.67	2.52

* Use ultra-low sulfur diesel fuel

Cooling System

Fan Load	0.67 hp (0.5 kW)
Coolant Capacity (with radiator)	2.3 gallons (8.8 liters)
Coolant Flow Rate (per minute)	20.1 gallons (76.0 liters)
Heat Rejection to Coolant (per minute)	1479 Btu (1.56 MJ)
Maximum Coolant Friction Head	14.5 psi (100 kPa)
Maximum Coolant Static Head	3.35 feet (1.04 meters)
Ambient Temperature Rating	104°F (40°C)

Air

Combustion Air	109 cfm (3.10 m ³ /min)
Maximum Air Cleaner Restriction	25 in. H ₂ O (6.23 kPa)
Alternator Cooling Air	388 cfm (11.0 m ³ /min)
Radiator Cooling Air	1420 cfm (40.2 m ³ /min)
Minimum Air Opening to Room	2.6 ft ² (0.24 m ²)
Minimum Discharge Opening	0.84 ft ² (0.08 m ²)

Exhaust System

Gas Flow (full load)	148 cfm (4.2 m ³ /min)
Gas Temperature	847°F (453°C)
Maximum Back Pressure	30.1 in. H ₂ O (7.5 kPa)

Amperage

Rated Voltage	Maximum Amps
1Ø 120 Volt	60 Amps x 2 (Zigzag)
1Ø 240 Volt	60 Amps (Zigzag)
3Ø 208 Volt	60 Amps
3Ø 240 Volt	60 Amps
3Ø 480 Volt	30 Amps
Main Line Circuit Breaker Rating	60 Amps
Over Current Relay Trip Set Point 480V Made Only	30 Amps

